

THNC-251, 301

HIGH POWER, HIGH SPEED TILTING ROTARY TABLES

The THNC-Series tables have a NC controlled rotary axis, and a manual tilt axis. The highly rigid body incorporates a powerful hydraulic clamp mechanism.



Model		THNC-251		THNC-301	
Tilt Range		0° ~ +93°			
Table diameter		250		320	
Table height at 0° position		230		265	
Center height at 90° position		210		235	
Center bore	Nose Diameter	40H7		40H7	
	Thru Diameter	32		40	
Table T-slot width		12H7		14H7	
Guide block width		18h7		18h7	
Servo motor (Fanuc)*		Rotary	Tilt	Rotary	Tilt
		Alpha 4i	Manual	Alpha 8i	Manual
Maximum motor speed	rpm	4,000	-	3,000	-
Speed reduction ratio		1/180	-	1/180	-
Maximum table speed	rpm	22.2	-	16.7	-
Inertia converted into motor shaft	x 10 ⁻³ kg·m ²	.24	-	.34	-
Clamp system		Hydraulic** @500psi	Manual @19.6 Nm (14.4 ft.lbs.)	Hydraulic** @500psi	Manual @35.3Nm (26 ft.lbs.)
Clamp torque	Nm (ft. lbs.)	490 (361)	490 (361)	833 (614)	1,862 (1,372)
Indexing accuracy	arc sec.	±7.5	±30	±7.5	±30
Indexing repeatability	arc sec.	±2	-	±2	-
Net Weight	kg (lbs.)	125 (275)		190 (418)	
Allowable wheel torque - rotary	Nm (ft. lbs.)	470 (346)		764 (563)	
Allowable work inertia	kg·m ²	.61		2.55	
Allowable work weight kg (lbs)	0° tilt angle	80 (176)		180 (396)	
	0° ~ 90° tilt angle	40 (88)		100 (220)	
Allowable load when table clamped	N (lbf)	6,860 (1,537)		9,800 (2,195)	
	Nm (ft. lbs.)	490 (361)		833 (614)	
	Nm (ft. lbs.)	490 (361)		1,470 (1,083)	

*Other motors & rpm available • Specifications subject to change without notice • Dimensions = mm • **Booster optional

Dimensions

Drawings not to scale • Dimensions = mm

THNC-251

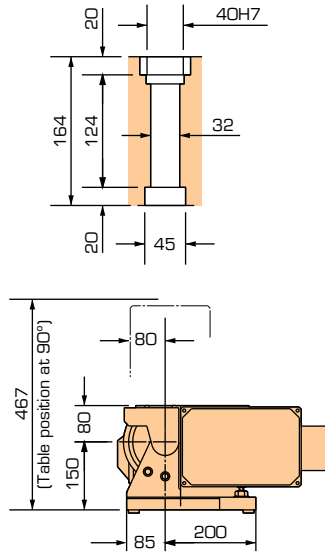
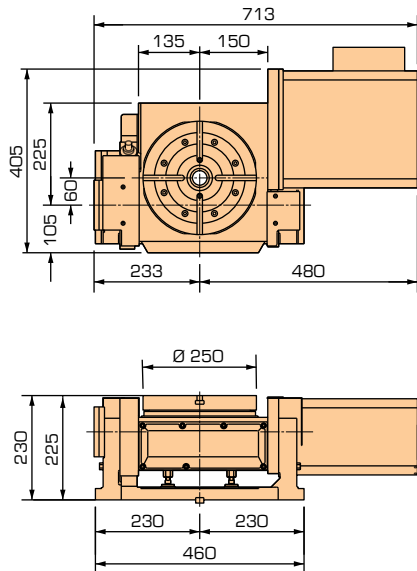

THNC-301

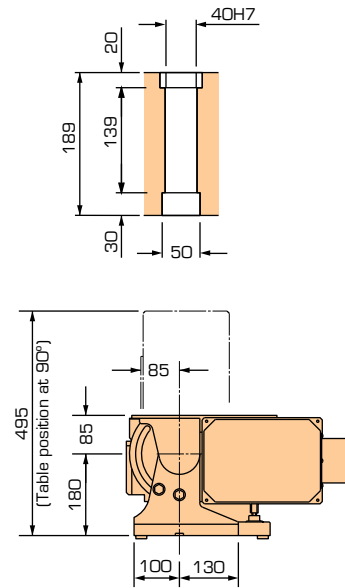
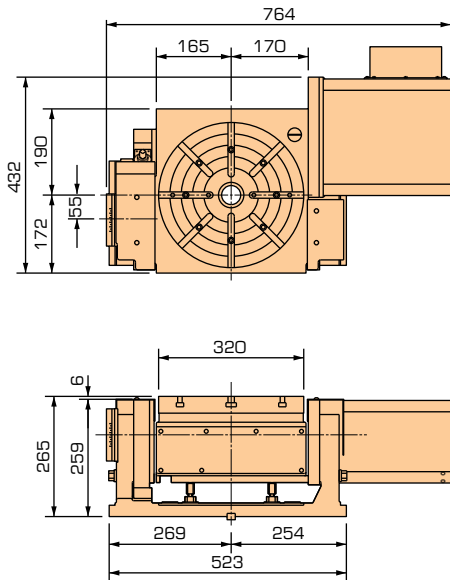

The dimensions above are for tables with a FANUC servo motor. Other motors available (dimensions may increase).

- **ACCESSORIES:**
Steel Braided Cable:
5 Layers of Protection



- **OPTIONAL TPC3 SERIES**
NC Controller



OPTIONS • ACCESSORIES

Table Model	Faceplate	TPC NC Controller	Various Chucks & Collets	PVC or Steel Braided Cables	Scales	Hydraulic Clamping	Air/Hydraulic Booster
THNC-251	Standard	TPC3 Series	Yes	Yes	Yes	Standard-Rotary	Yes
THNC-301	Standard	TPC3 Series	Yes	Yes	Yes	Standard-Rotary	Yes