



# DMTRT SERIES PROGRAMMABLE OR TRUE 4th/5th TILT/ROTARY TABLE



DMTRT-320



DMTRT-140



UDNC-M2

CNC ROTARY PRODUCTS

**STANDARD ACCESSORIES INCLUDE:**

- ▶ UDNC-M2 Dual Axis Controller
- ▶ Motor/Encoder cables Power cable (105~240VAC, 20 Amp)
- ▶ T-slotted Face Plate
- ▶ Remote cable fro M-Code interface,
- ▶ operator's manual & warranty card
- Locating keys

The DMTRT Series Tilt/Rotary tables are available in the following combinations:

**OPTION 1:** Programmable tilt and rotary axes complete with UDNC-M2 dual axis controller.

**OPTION 2:** Full fourth axis (rotary) using Fanuc, Mitsubishi, Yaskawa, etc. motors, and programmable 5th axis (tilt) using our UDNC-M1 single axis controller.

**OPTION 3:** Full fourth (rotary) and fifth (tilt) axes using Fanuc, Mitsubishi, Yaskawa, etc. motors on both axes.

Inch/(mm)

MODEL	DMTRT 140		DMTRT 170		DMTRT 220		DMTRT 280		DMTRT 320	
Sub Table O.D.	5.51 (140)		6.69 (170)		8.66 (220)		11.02 (280)		12.69 (320)	
Upper height of table	13.26 (337)		11.42 (290)		11.81 (300)		14.57 (370)		14.96 (380)	
Center Height @90°	5.51 (140)		8.27 (210)				10.63 (270)			
Tilting angle range	-20° ~ +110°									
Through hole diameter	1.26 (32)		1.77 (45)		2.50 (63.5)		3.54 (90)		4.33 (110)	
Table T-slot width	0.47 (12)									
Guide block Width x Height	0.71 X 0.27									
Total Gear ratio	rotary	tilt	rotary	tilt	rotary	tilt	rotary	tilt	rotary	tilt
	72:1	120:1	72:1	360:1	90:1	360:1	180:1	360:1	180:1	360:1
Max.Rotation speed (RPM)	62.5	33.3	48	10	38	10	20	10	20	10
Clamping Method	hydraulic				Pneumatic 70 ~ 100 psi					
	rotary	tilt	rotary	tilt	rotary	tilt	rotary	tilt	rotary	tilt
Spindle Brake Torque ft-lbs. (kg-m)	65 (88)	260 (353)	108 (147)	612 (830)	181 (245)	870 (1180)	325 (440)	1370 (1860)	479 (650)	1370 (1860)
Positioning Accuracy	22.5"	30"	22.5"	30"	22.5"	30"	22.5"	30"	22.5"	30"
Repeatability	6"	10"	6"	10"	6"	10"	6"	10"	6"	10"
Max cutting torque ft-lbs. (N-m)	58 (78.5)		37 (50)		52 (70)		218 (295)		218 (295)	
Max work load capacity lbs. (kg)	55 (25)		133 (60)		200 (91)		265 (120)		330 (150)	
Max Thrust load lbs. (kg) (horizontal)	1367 (620)		1320 (600)		2200 (1000)		3300 (1500)		4860 (2200)	
Max work inertia lbs/in.sec² (kg/cm.sec²)	1.17 (3.18)		0.043 (0.21)		0.111 (0.54)		0.242 (1.18)		0.393 (1.92)	
Net weight of table lbs. (Kg)	213 (97)		440 (200)		530 (240)		770 (350)		858 (390)	

The DMTRT models clearly use the latest technology. ■ With this type of product, rigidity of the tilting axis is one of the most important factors. In addition, these dual disc pneumatic brakes are positioned as close to the axis of rotation as possible, to provide the maximum holding torque. ■ Brushless digital AC servo motors are used, for maximum torque and very efficient servo performance. ■ A multiple gear arrangement is used on the tilting axis to prevent uneven wear. ■ Seals are critical to prevent coolant damage to the servo and gear box; the DMTRT uses the latest in seal technology, featuring spring loaded double lip oil seals around all main spindle housings. ■ Heavy duty steel conduit shielded motor cables, virtually eliminate noise interference to the controller and servos.

# DIMENSIONAL SPECIFICATIONS:

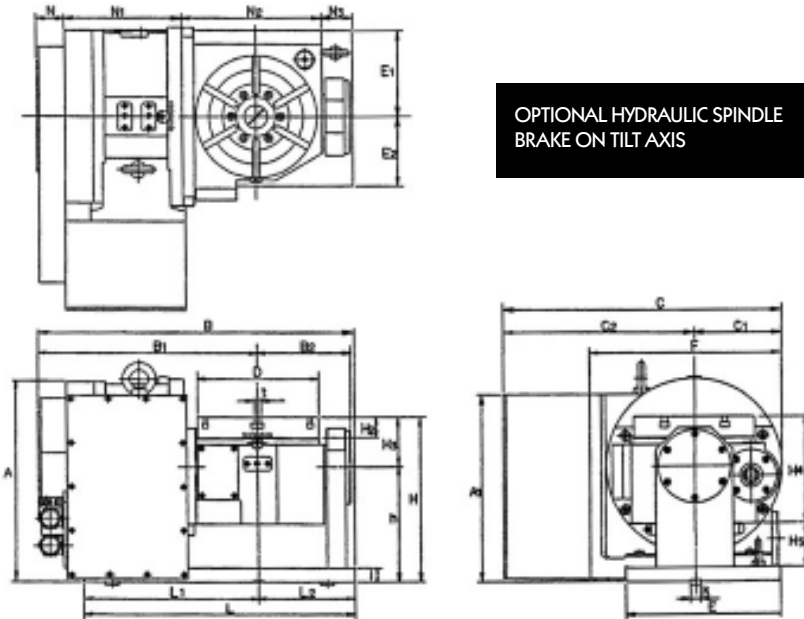

Call for dimensional data on DMTRT-140.

Inch/(mm)

	D	E	E1	E2	F	h	H	H2	H3	H4
DMTRT-170	6.69 (170)	11.02 (280)	6.10 (155)	4.92 (125)	13.38 (340)	8.27 (210)	11.42 (290)	1.38 (35)	3.15 (80)	6.69 (170)
DMTRT-220	8.66 (220)	11.02 (280)	6.10 (155)	4.92 (125)	13.78 (350)	8.27 (210)	11.81 (300)	1.49 (38)	3.54 (90)	7.67 (195)
DMTRT-280	11.02 (280)	12.99 (330)	7.08 (180)	5.90 (150)	16.53 (420)	10.63 (270)	14.56 (370)	1.69 (43)	3.94 (100)	8.66 (220)
DMTRT-320	12.60 (320)	12.99 (330)	7.08 (180)	5.90 (150)	16.73 (425)	10.63 (270)	14.96 (380)	1.89 (48)	4.33 (110)	9.64 (245)

	H5	I	K	L	L1	L2	N	N1	N2	N3
DMTRT-170	3.74 (95)	0.98 (25)	0.71 (18)	17.71 (450)	11.42 (290)	6.30 (160)	1.97 (50)	8.27 (210)	8.27 (210)	2.36 (60)
DMTRT-220	3.15 (80)	0.98 (25)	0.71 (18)	19.29 (490)	12.40 (315)	6.89 (175)	1.97 (50)	8.27 (210)	10.04 (255)	2.16 (55)
DMTRT-280	4.72 (120)	1.18 (30)	0.71 (18)	22.05 (560)	13.97 (355)	8.07 (205)	1.97 (50)	8.86 (225)	12.40 (315)	2.36 (60)
DMTRT-320	4.13 (105)	1.18 (30)	0.71 (18)	23.62 (600)	14.76 (375)	8.86 (225)	1.97 (50)	8.86 (225)	13.97 (355)	2.36 (60)

	A	A1	B	B1	B2	C	C1	C2
DMTRT-170	14.17 (360)	13.38 (340)	20.86 (530)	14.56 (370)	5.90 (150)	19.68 (500)	5.90 (150)	13.78 (350)
DMTRT-220	14.56 (370)	13.38 (340)	22.44 (570)	15.55 (395)	6.69 (170)	20.08 (510)	6.30 (160)	13.78 (350)
DMTRT-280	18.50 (470)	13.35 (390)	25.59 (650)	17.52 (445)	7.87 (200)	23.82 (605)	7.87 (200)	15.94 (405)
DMTRT-320	18.50 (470)	13.35 (390)	27.16 (690)	18.31 (465)	8.66 (220)	24.02 (610)	8.07 (205)	15.94 (405)

We developed the UDNC-M2 multi-axis controller for the DMTRT product line. This offers a host of features, such as "open architecture" programming system (M&G Code or Conversational) with a built-in PLC ■ fully synchronous multi-axis movements ■ Dual encoder feedback outputs, for high accuracy. ■ Pitch error compensation to program out worm gear error ■ All standard functions: Jog, Remote start and finish, Home set, Home return, Work home set, Work home return, E stop, and a host of others. ■ Digital amplifier provides for ultra-smooth servo performance throughout the entire RPM range ■ DMTRT can be totally operated from the CNC machine via an RS232 cable connection between the VMC and UDNC-M2. CNC user Macro is used to command position between the VMC and UDNC-M2. (Please see pg.11 for MACRO programming).

CNC ROTARY PRODUCTS



# DMTRT SERIES 2-SPINDLE TILTING ROTARY TABLE

### FEATURES:

- ▶ Two spindle models available in 140mm and 170mm table diameter sizes
- ▶ Very compact design
- ▶ Can be supplied as programmable style (using UDNC-M2) or as full fourth or fifth axis, using FanucMitsubishi, Yaskawa, or other motors
- ▶ High torque dual disc brake design with loading ring for maximum rigidity, permitting heavy cutting
- ▶ Class "A" dual tapered roller spindle bearings providing for smooth rotation even under the heaviest thrust loads



DMTRT-140-2



UDMC-M2

CNC ROTARY PRODUCTS

MODEL		DMTRT 140-2	DMTRT 170-2
SUB TABLE D.		5.51 (140)	6.69 (170)
CENTER HEIGHT @90°		8.27 (210)	8.27 (210)
MAX RPM	ROTARY	55.5	55.5
	TILTING	11.1	11.1
SPINDLE TORQUE ft-lbs (kg-m)	ROTARY	30 (41)	37 (51)
	TILTING	188 (26)	188 (26)
GEAR RATIO	ROTARY	72 : 1	72 : 1
	TILTING	360 : 1	360 : 1
MAX WORK LOAD CAPACITY lbs (kg)	0° (horizontal)	110 (50)	132 (60)
	@ 90°	55 (25)	66 (30)
RESOLUTION DEGREE		0.000625	0.000625
SPINDLE BRAKE TORQUE lbs (kg-m)	ROTARY	65 (9)	108 (15)
	TILTING	615 (85)	868 (120)
MAX WORK INERTIA lbs/inch/sec <sup>2</sup> (kg/cm/sec <sup>2</sup> )		1.24 (1.43)	1.86 (2.14)
MAX TRUST LOAD lbs (kg) (horizontal)		1100 (500)	1320 (600)
MAX CUTTING TORQUE lbs.(kg)	TILTING	80 (11)	108 (15)
	BRAKE ON	217 (30)	289 (40)
INDEXING ACCURACY	ROTARY	+/- 22.5 seconds	
	TILTING	+/- 30 seconds	
REPEATABILITY		6 seconds	
SPINDLE THRU HOLE DIA.		1.26 (32)	1.77 (45)
NET WEIGHT lbs (kg)		441 (200)	529 (240)

**DIMENSIONAL SPECIFICATIONS**

**EACH UNIT SUPPLIED WITH:**

- ▶ UDNC-M2 controller for DMTRT
- ▶ DMTRT unit complete with rotary drive unit, end support and mounting plate
- ▶ Power cable (105~240 single phase VAC, 20 Amp)
- ▶ Remote cable for M-code interface to CNC
- ▶ Operator's manual, test report, warranty card and locating keys

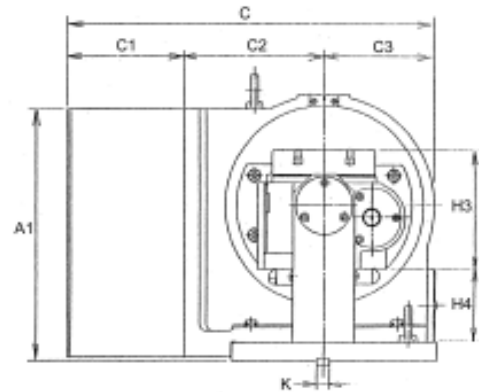
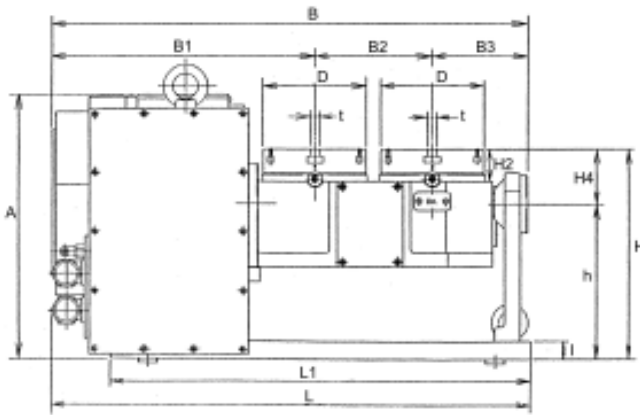
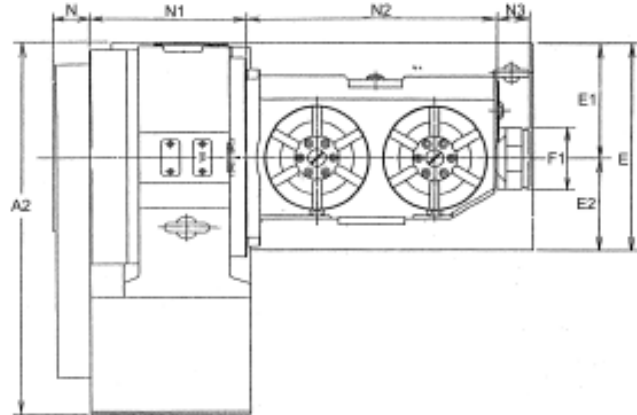

Inch (mm)

MODEL	A	A1	A2	B	B1	B2	B3	C	C1	C2	C3
DMTRT140-2	14.17 (360)	13.39 (340)	19.88 (505)	25.39 (645)	13.98 (355)	6.3 (160)	5.12 (130)	19.69 (500)	6.3 (160)	7.48 (190)	5.91 (150)
DMTRT170-2	14.37 (365)	13.39 (340)	19.88 (505)	28.54 (725)	14.57 (370)	7.87 (200)	6.10 (155)	19.88 (505)	6.3 (160)	7.48 (190)	6.10 (155)

MODEL	D	E	E1	E2	F	h	H	H2	H3	H4
DMTRT140-2	5.51 (140)	11.02 (280)	6.10 (155)	4.92 (125)	3.31 (84)	8.27 (210)	11.22 (285)	1.34 (34)	6.30 (160)	3.94 (100)
DMTRT170-2	6.69 (170)	11.02 (280)	6.10 (155)	4.92 (125)	5.12 (130)	8.27 (210)	11.4 (290)	1.38 (35)	6.69 (170)	3.74 (95)

MODEL	I	K	t	L	L1	N	N1	N2	N3
DMTRT140-2	0.98 (25)	0.708 (18)	0.47 (12)	25.59 (650)	22.44 (570)	1.97 (50)	8.27 (210)	13.39 (340)	1.77 (45)
DMTRT170-2	0.98 (25)	0.708 (18)	0.47 (12)	28.74 (730)	25.59 (650)	1.97 (50)	8.27 (210)	16.54 (420)	1.77 (45)

CNC ROTARY PRODUCTS